



***Open to
Innovation***

Rf-Technologies



Facts

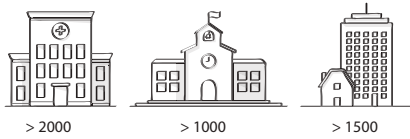

> 2000

> 1000

> 1500

4500 fire safe buildings!

Between 2013 and 2016, we helped make over 4500 buildings fire safe: health, education and other buildings, ranging from offices to leisure, culture and housing!



15% of our staff in R&D

This gives evidence of our willingness to continuously extend and improve our product range.



100 fire tests per year

Or an average of 1 fire test every second working day.

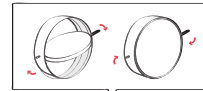

1.000.000 cycle tests per year

These tests are performed by Rf-Technologies to assess the **durability of the finished products** with mechanisms.

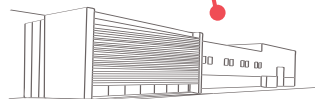

Rf-Technologies
Headquarters, Belgium



Production unit Slovakia

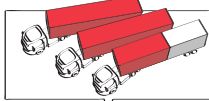

2,5 orders picked

up every hour
Just over 4.700
pick-ups per year!

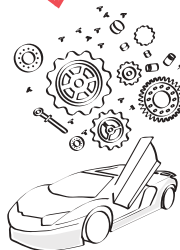

A Lamborghini Aventador Carbonado...
...is worth € 1,3 million: that is also the value of the **3,8 million parts** stored in our warehouse.

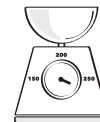

An Airbus A340-300...
...weighs **268.000 kg**: this is the **total weight** of metal sheets used each year to manufacture our products.

Figures

Closed to fire

At Rf-Technologies, we design innovative solutions that provide our customers with efficient passive fire protection.

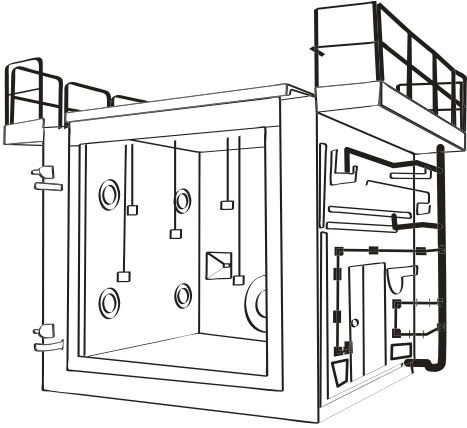

Two test ovens

to carry out fire tests in-house, which helps us:

- shorten the development time
- optimise the products
- guarantee consistent fire performance of the products



Our focus on a specialised range allows us to provide our customers with cutting-edge solutions for passive fire protection.



A specialist you can trust

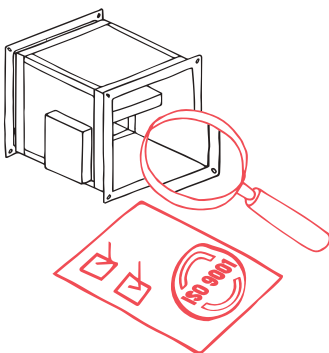

Founded in 1985
ISO9001:2015 quality standard

The company employs 170 people in its two sites in Belgium (headquarters) and Slovakia. Rf-Technologies solutions are designed and approved for all types of walls: vertical and horizontal, in concrete or lightweight materials.

They are compliant with the most stringent local and European standards. In its pioneering role in the field of compliance with international standards, Rf-Technologies has been testing its products according to the European test criteria since 2004.

The company was the first supplier to propose a complete range of CE marked fire dampers in February 2012.

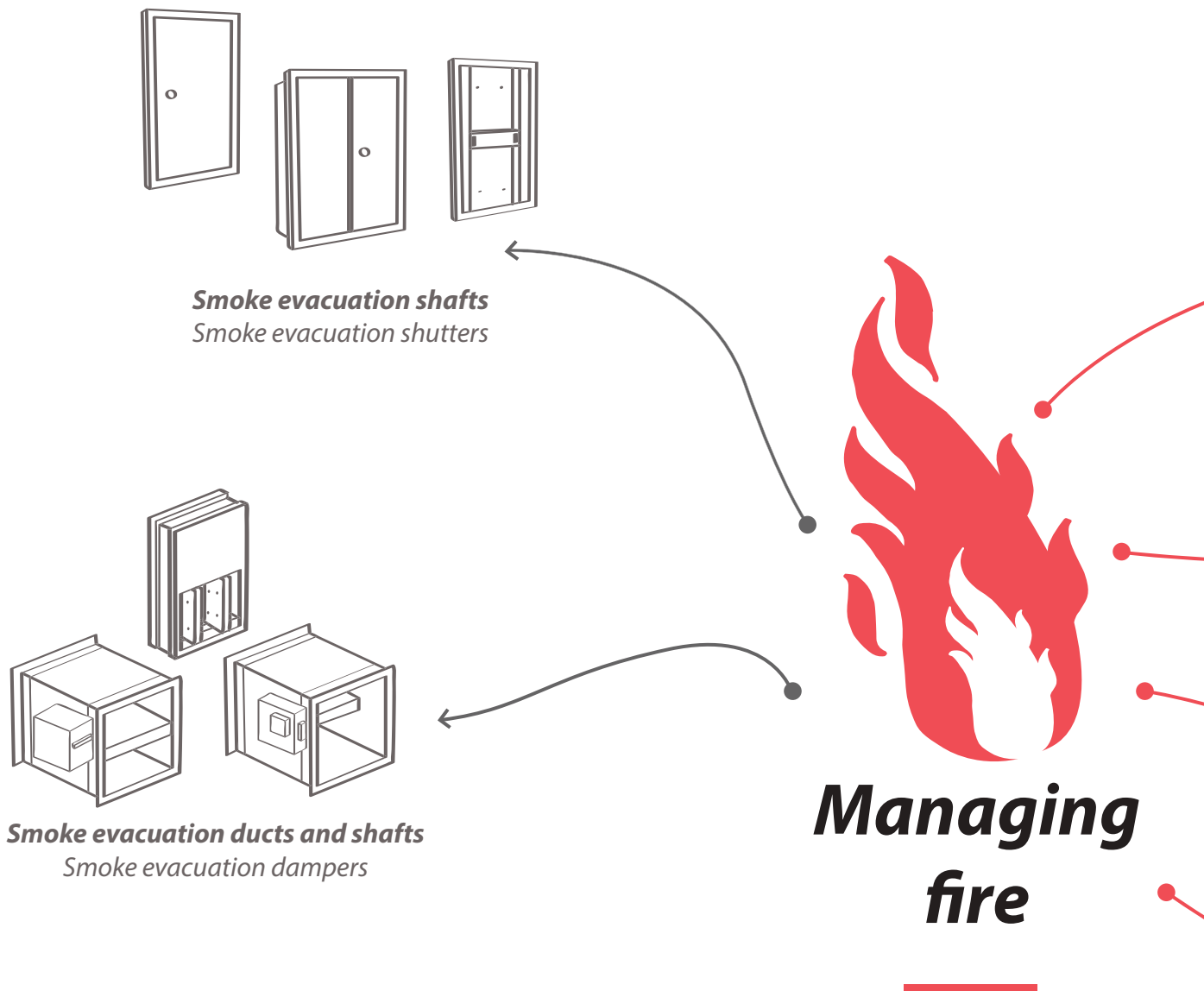

Smoke evacuation

Smoke is considered to be as dangerous as fire, if not more. Smoke evacuation solutions are designed to evacuate smoke and heat in case of fire. They create a smoke-free zone to facilitate the evacuation of people under good visibility conditions.

Rf-Technologies smoke evacuation shutters and dampers are normally closed, and open locally in the event of fire.

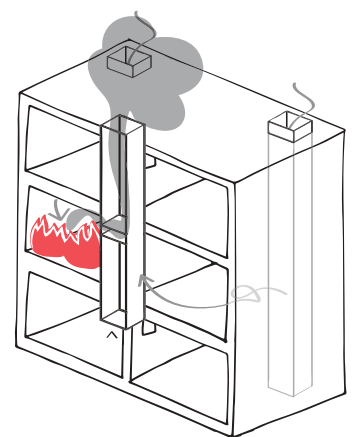

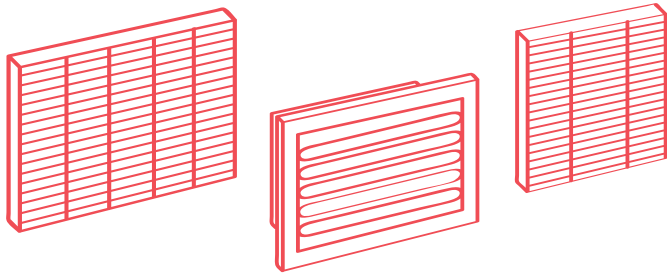

Natural ventilation

Fire resistant grills with neutral or aesthetic finish

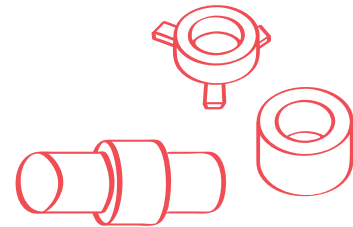

Flammable ducts

Fire resistant collars, cast-in or wall-mounted

Mechanical ventilation

Fire dampers and fire damper cartridges with superior aeraulic qualities

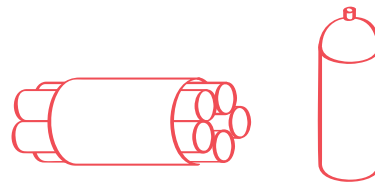
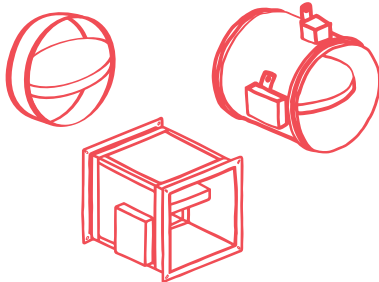

Wall penetrations

Sealing material

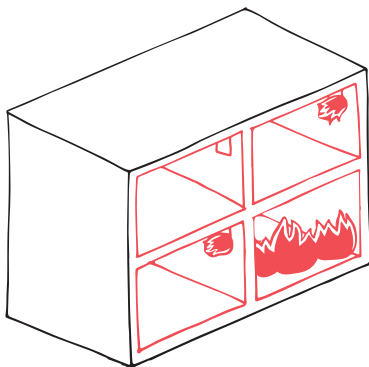
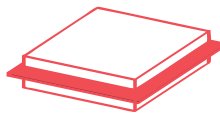

Compartmentation

Fire compartmentation is the division of a building into compartments, which are designed to contain the fire. A fire compartment is separated from the remainder of the building by a continuous construction that stops the fire for a certain period of time.

In order to ensure the integrity of the fire compartment, every opening through its walls and floors should be protected to resist the passage of fire.

Simplicity across all steps



Planning

The Rf-t range covers most of your specialist needs for compartmentation and smoke evacuation with an extensive choice in terms of sizes, wall types and mechanisms. Selection tools are available to help you choose the optimal solution based on air-flow needs.

A **timely delivery** is key to the success of your projects. Be it a large-scale project where the elements must be installed in a pre-established order or an urgent replacement, you can trust our reliable delivery times.



Construction

In order to comply with their classification documents, fire resistant elements must be installed in accordance with the tested device: depending on the wall type, the installation and sealing processes described in the classification report must be respected carefully.

To make the installation as easy as possible, we strive to use **standard construction products** for the sealing of the opening during a fire test.

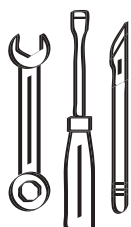

Maintenance and support

Most Rf-t products are maintenance-free. What's more, the upgradeable mechanisms make it possible to modify the solution during its lifecycle, in accordance with budgetary and regulatory requirements.

Our **dedicated team** is available to help our customers and international distributors via telephone, e-mail or fax, while a network of local distributors provides sales and technical support to end-users.

Truly European

The company markets its products through a wide network of partners in over fifteen European countries. Our solutions are distributed under the Rf-Technologies brand name, or as private label solutions.

Our compartmentation and smoke evacuation products guarantee the safety of commercial and institutional buildings all over Europe: **office buildings, hospitals, museums, government buildings, and shopping centres.**

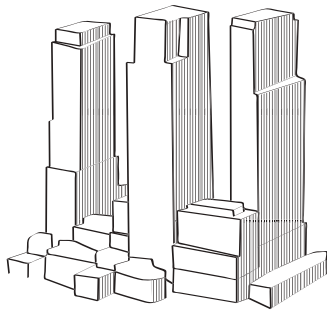

JuBi Towers, The Hague (NL)



Gardermoen Airport, Oslo (NO)

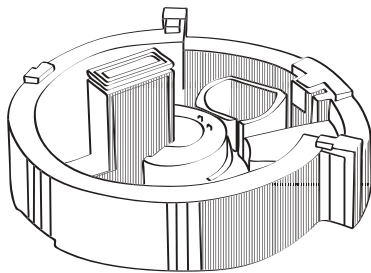

**Maison de la
Radio, Paris (FR)**

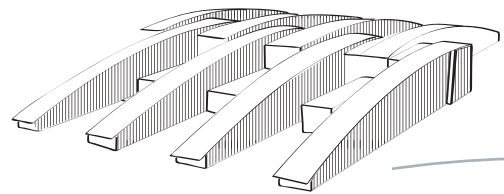

NATO Headquarters, Brussels (BE)



Hospital Particular, Alvor (PO)

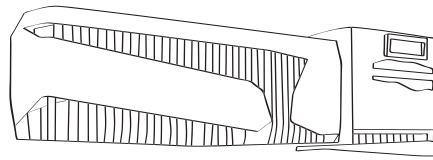

**Centrul Comercial
Mercur, Craiova (RO)**

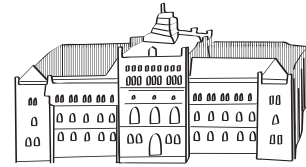

**Polytechnic Institute,
Riga (LV)**



**Müpa (Palace of Arts),
Budapest (HU)**

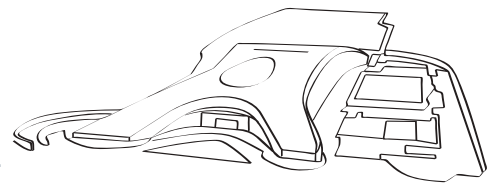

Sterjarii Country Club, Bucharest (RO)

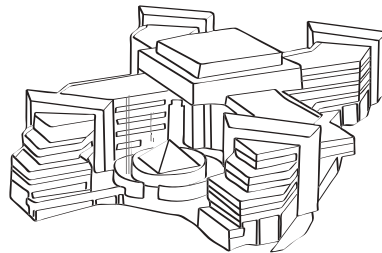

**BGL BNP Paribas,
Luxembourg (LU)**

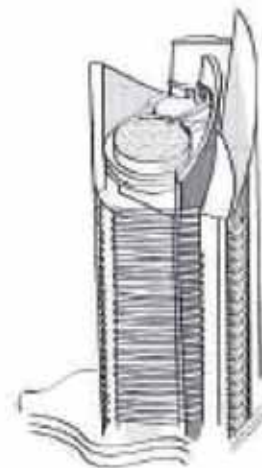

Odeon Towers, Monaco (MC)

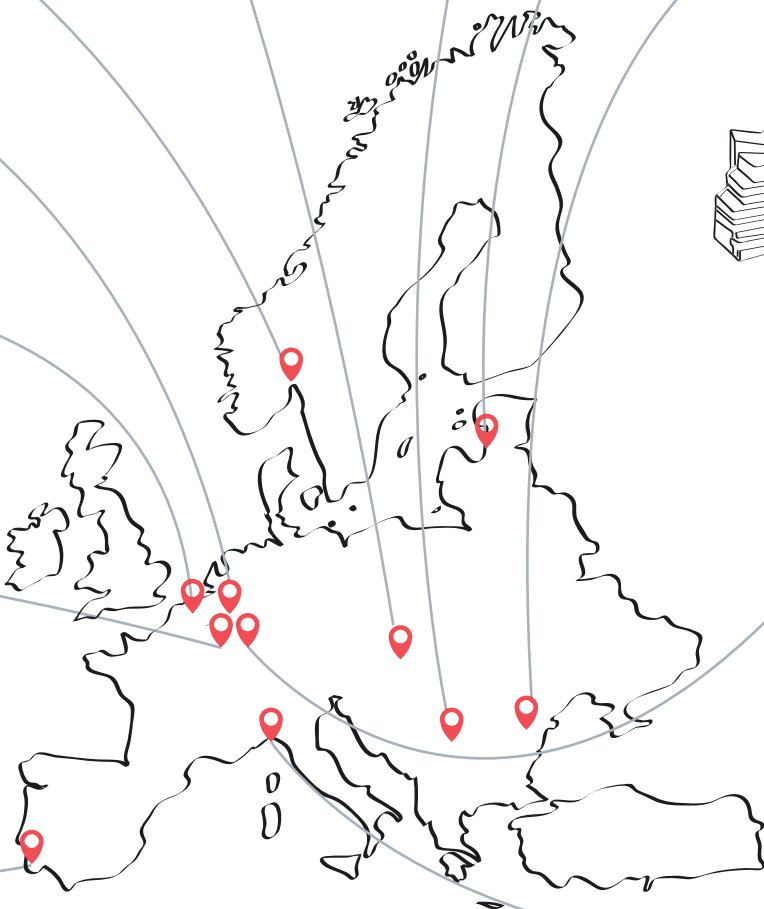



Closed to Fire

RF-Technologies
T: +32 9 362 31 71
F: +32 9 362 33 07
E: info@rft.be

Lange Ambachtstraat 40
B-9860 Oosterzele
Belgium