

# CU2-15

Rectangular fire damper 120' at 1500 Pa

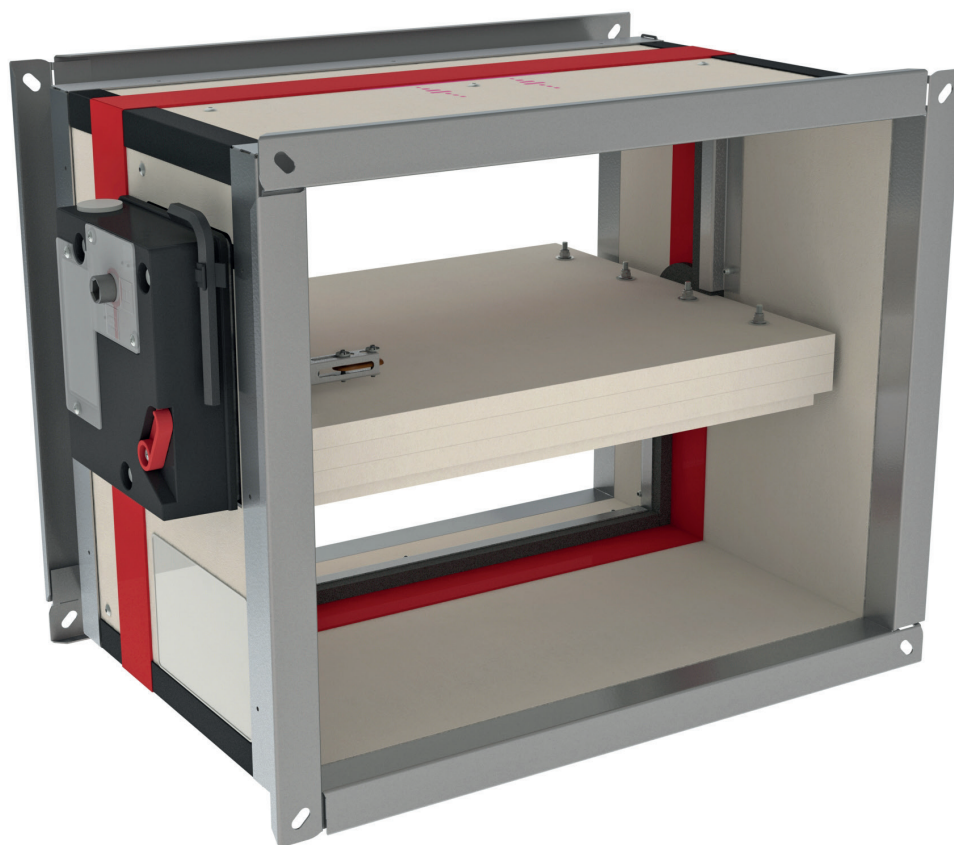



## Table of content

Declaration of performance	3
Product presentation CU2-15	4
Range and dimensions CU2-15	4
Variant CU2-15L	5
Range and dimensions CU2-15L	5
Evolution - kits	6
Options - at the time of order	9
Flange types - at the time of order	9
Storage and handling	11
Installation	11
Installation at a minimal distance from another damper or from an adjacent supporting construction	12
Installation in rigid wall	13
Operation and mechanisms	14
Electrical connection	19
Weights	21
Selection data	24
Example	25
Sample order	28
Approvals and certificates	28

## Explanation of the abbreviations and pictograms

Wn = nominal width	E.TELE = power supply magnet	Sn = free air passage
Hn = nominal height	E.ALIM = power supply motor	$\zeta$ [-] = pressure loss coefficient
Dn = nominal diameter	V = volt	Q = airflow
E = integrity	W = watt	$\Delta P$ = static pressure drop
I = thermal insulation	Auto = automatic	v = air speed in the duct
S = smoke leakage	Tele = remote controlled	Lwa = A-weighted sound power level
Pa = pascal	Pnom = nominal capacity	Lw oct = sound power level per octave midband
ve = vertical wall penetration	Pmax = maximum capacity	dB(A) = A-weighted decibel value
ho = horizontal floor penetration	GKB (type A) / GKF (type F): "GKB" stands for standard plasterboards (type A according to EN 520) while "GKF" plasterboards offer a higher fire resistance for a similar plate thickness (type F according to EN 520)	$\Delta L$ = correction factor
o -> i = meets the criteria from the outside (o) to the inside (i)	Cal-Sil = calcium silicate	
i <-> o = fire side not important	OP = option (delivered with the product)	
V AC = Volt alternating current	KIT = kit (delivered separately for repair or upgrade)	
V DC = Volt direct current	PG = connection flange to the duct	

	fire resistance tested at a negative pressure of 1500 Pa		suitable for built-in installation
	intermediate dimensions on request		

# DECLARATION OF PERFORMANCE

CE\_DoP\_Rf-t\_G7\_EN - F-01/01/2024

1. Unique identification code of the product-type:		CU2-15	
2. Intended use/s:		Rectangular fire damper to be used in conjunction with partitions to maintain fire compartments in heating, ventilating and air conditioning installations.	
3. Manufacturer:		Rf-Technologies NV, Lange Ambachstraat 40, B-5860 Oosterzele	
4. System/s of AVCP:		System 1	
5. Harmonised standard / European Assessment Document; notified body / European Technical Assessment, Technical Assessment Body, notified body; certificate of constancy of performance:		EN 15650:2010; BCCA with identification number 0749;0749-CPE-BC1-606-0464-15650.04-046482517	
6. Declared performance according to EN 15650:2010		(Fire resistance according to EN 1366-2 and classifications according to EN 13501-3)	
<b>Essential characteristics</b>			
<b>Range</b>	<b>Type</b>	<b>Wall</b>	<b>Sealing</b>
200x200 mm ≤ CU2-15 ≤ 1200x800 mm	Rigid wall	Reinforced concrete ≥ 110 mm	Mortar
1 Type of installation: built-in 0/180°			
<b>Nominal activation conditions/sensitivity:</b>		Pass	
Response delay (response time): closure time		Pass	
Operational reliability: cycling		CFTH - 50 cycles; MANO - 300 cycles; BL(F)(T) - 10000 cycles; BFN(T) - 10000 cycles; ONE - 10000 cycles; ONE-X - 10000 cycles; UNIQ - 10000 cycles	
Durability of response delay:		Pass	
Durability of operational reliability:		Pass	
Protection against corrosion according to EN 60068-2-52:		Pass	
Damper casing leakage according to EN 1751:		≥ class B	

The performance of the product, identified above is in conformity with the set of declared performance/s. This declaration of performance is issued, in accordance with Regulation (EU) No 305/2011, under the sole responsibility of the manufacturer identified above.

Signed for and on behalf of the manufacturer by:  
**Frank Verlinden**, Head of Product Management



*Frank Verlinden*

Oosterzele, 01/01/2024

Harmonised standard  
 EN 15650:2010

Installation	Performance Classification
1	EI 120 (V <sub>e,i</sub> ↔ o) S - (1500 Pa)



**Product presentation CU2-15**

Rectangular fire damper with a 120 minutes fire resistance in concrete walls with air pressure up to 1500 Pascal. Its refractory casing is made of asbestos free panels, which are resistant to humidity.

Fire dampers are installed where air ducts penetrate fire-resistant compartment walls. Their role is to restore the fire resistance grade of the penetrated wall and to prevent smoke propagation. Fire dampers are distinguished by their degree of fire resistance, by their aerulic properties as well as by their installation ease. Rf-Technologies' fire dampers are all CE marked. They can be equipped with various types of mechanisms depending on the specific needs linked to the project or to the local regulations.

fire resistance tested at a negative pressure of 1500 Pa



- suitable for built-in installation
- air tightness in accordance with EN 1751: class B (class C in option)
- tested in accordance with EN1366-2 up to 1500 Pa
- operating mechanism outside the wall
- maintenance-free
- for indoor use
- operating temperature: max. 50°C
- intermediate dimensions on request
- suitable for installation in rigid wall

1. connection flange PG30
2. casing made of refractory material
3. damper blade
4. operating mechanism
5. sealing cold smoke
6. blade bumper
7. intumescent strip
8. transmission with locking (open/closed)
9. fusible link
10. product identification

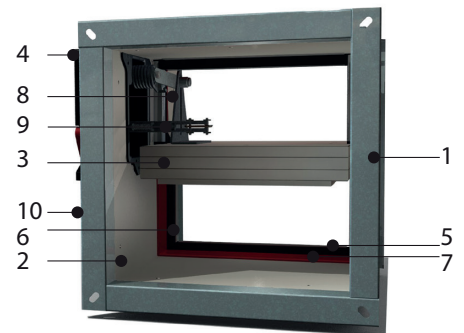

**Range and dimensions CU2-15**

Wn/Hn in steps of 50 mm; intermediate dimensions are subject to extra cost (heights between  $\geq 275$  and  $\leq 299$  mm are not possible). Exceeding blade: X = on the mechanism side, Y = on the wall side

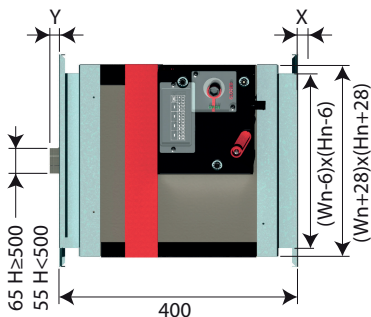

Hn (mm)	300	350	400	450	500	550	600	650	700	750	800
x	-	-	-	-	-	-	25	50	75	100	125
y	1	26	51	51	101	126	151	176	201	226	251

	N	M
(W x H) mm	200x200	1200x800

## Variant CU2-15L

Damper with a tunnel casing extension at one or both sides so that the damper blade does not exceed the tunnel. This version allows to connect a grill or a bend directly on the damper flange or to use a circular connection.

## Range and dimensions CU2-15L

Wn/Hn in steps of 50 mm; intermediate dimensions are subject to extra cost (heights between  $\geq 275$  and  $\leq 299$  mm are not possible). Exceeding blade: X = on the mechanism side, Y = on the wall side

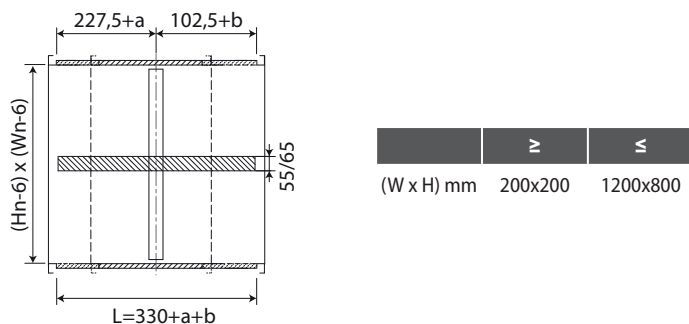

Hn < 300 mm



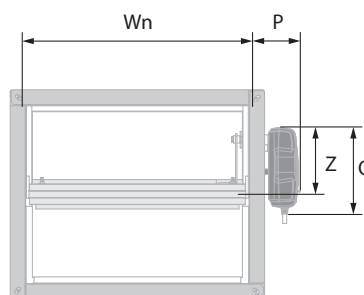
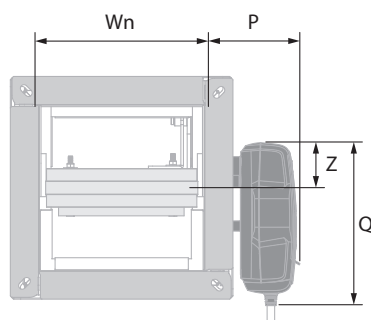

Hn ≥ 300 mm



	CFTH	ONE (X)	BFL(T)		CFTH	ONE (X)	BFL(T)	BFN(T)
<b>P</b>	78	104	96	<b>P</b>	78	104	96	100
<b>Q</b>	180	191	110	<b>Q</b>	180	191	110	110
<b>Z</b>	62	47	74	<b>Z</b>	157	147	180	180

## Evolution - kits

	<b>KIT ONE T 24 FDCB</b>	Spring return actuator ONE 24V (with fusible link T) + bipolar beginning- and end-of-range switch
	<b>KIT ONE T 24 FDCU</b>	Spring return actuator ONE 24V (with fusible link T) + unipolar beginning- and end-of-range switch
	<b>KIT ONE T 24 FDCU ST</b>	Spring return actuator ONE 24V (with fusible link T) + unipolar beginning- and end-of-range switch + plug (ST)
	<b>KIT ONE T 230 FDCB</b>	Spring return actuator ONE 230V (with fusible link T) + bipolar beginning- and end-of-range switch
	<b>KIT ONE T 230 FDCU</b>	Spring return actuator ONE 230V (with fusible link T) + unipolar beginning- and end-of-range switch
	<b>KIT ONE T 230 FDCU ST</b>	Spring return actuator ONE 230V (with fusible link T) + unipolar beginning- and end-of-range switch + plug (ST)
	<b>KIT ONE-X 24</b>	Spring return actuator ONE-X 24V (with fusible link T)
	<b>KIT ONE-X 230</b>	Spring return actuator ONE-X 230V (with fusible link T)
	<b>KIT CFTH</b>	Automatic unlocking mechanism CFTH with FCU and without FTH 72

	<b>KIT BFL24</b>	Spring return actuator BFL 24V
	<b>KIT BFL24-ST</b>	Spring return actuator BFL 24V with plug (ST)
	<b>KIT BFL230</b>	Spring return actuator BFL 230V
	<b>KIT BFLT24</b>	Spring return actuator BFL 24V with thermo-electric fuse (T)
	<b>KIT BFLT24-ST</b>	Spring return actuator BFL 24V with thermo-electric fuse (T) and plug (ST)
	<b>KIT BFLT230</b>	Spring return actuator BFL 230V with thermo-electric fuse (T)
	<b>KIT BFLT230-ST</b>	Spring return actuator BFL 230V with thermo-electric fuse (T)
	<b>KIT BFN24</b>	Spring return actuator BFN 24V
	<b>KIT BFN24-ST</b>	Spring return actuator BFN 24V with plug (ST)



**KIT BFN24**

Spring return actuator BFN 24V (BFN kits must be used instead of BFL kits for fire dampers produced before 1/7/2015)

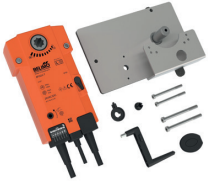

**KIT BFN230**

Spring return actuator BFN 230V

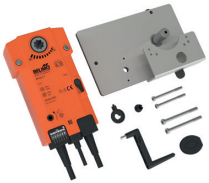

**KIT BFNT24**

Spring return actuator BFN 24V with thermo-electric fuse (T)

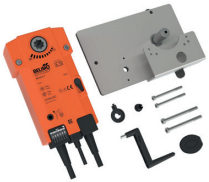

**KIT BFNT24-ST**

Spring return actuator BFN 24V with thermo-electric fuse (T) and plug (ST)

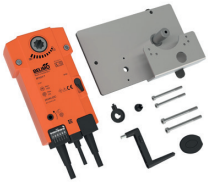

**KIT BFNT230**

Spring return actuator BFN 230V with thermo-electric fuse (T)

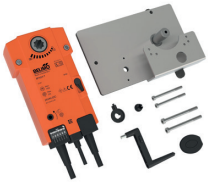

**KIT BFNT230-ST**

Spring return actuator BFN 230V with thermo-electric fuse (T)



**KIT BF24**

Spring return actuator BF 24V (BF kits must be used instead of BFN kits for fire dampers produced before 1/7/2015)



**KIT FDC CFTH**

1 limit switch (FCU/DCU/FCB/DCB)



**KIT SN2 BFL/BFN**

Auxiliary limit switch 'open/closed'





**KIT FTH72**

Fusible link FTH 72°C (for CFTH)



**KIT ZBAT 72**

Black spare part for thermo-electric fuse for BFLT/BFNT



**FUS72 ONE**

Fusible link 72°C



**MECT**

Testbox for mechanisms 24/48 V (magnet, motor, beginning and end of range switches)

Options - at the time of order



**EN1751\_C**

Air-tightness class C

Flange types - at the time of order

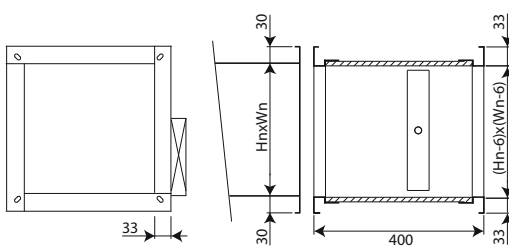

**PG30**

Connection to ducts with 30 mm flanges (either by sliding profile, or with bolts, or with clamps). Elliptical holes  $\varnothing$  8,5 x 16 mm.

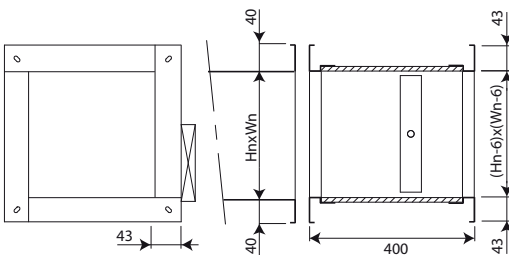

**PG40**

Connection to ducts with 40 mm flanges (either by sliding profile, or with bolts, or with clamps). Elliptical holes  $\varnothing$  8,5 x 16 mm.

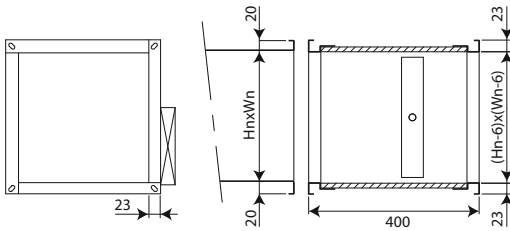

**PG20**

Connection to ducts with 20 mm flanges (either by sliding profile, or with bolts, or with clamps). Elliptical holes  $\varnothing 6,5 \times 16$  mm.

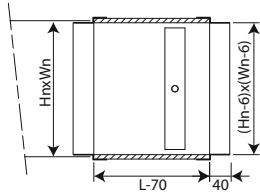

**PM**

Connection to ducts by insertion. This type of frame is used in case of lack of space for a standard PG30 frame.

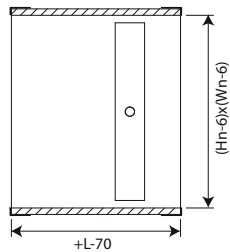

**PP**

No connection. This type of frame is used on one side of a damper that ends into a room.

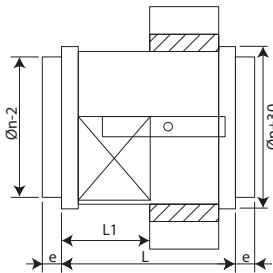

**PRJ**

Circular connection with rubber sealing ring.

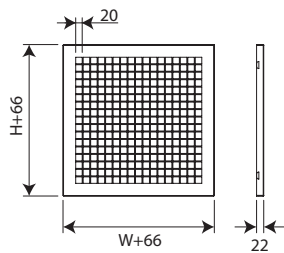

**PPT**

Grill. Very well suited as protection grill on the end piece of a duct system.

## Storage and handling

As this product is a safety element, it should be stored and handled with care.

### Avoid:

- any kind of impact or damage
- contact with water
- deformation of the casing

### It is recommended:

- to unload in a dry area
- not to flip or roll the product to move it
- not to use the damper as a scaffold, working table, etc.
- not to store smaller dampers inside larger ones

## Installation

### General points

- The installation must comply with the installation manual and the classification report.
- Axis orientation: see the declaration of performance.
- Avoid obstruction of adjoining ducts.
- Product installation: always with closed damper blade.
- Verify if the blade can move freely.
- Please observe safety distances with respect to other construction elements. The operating mechanism must also remain accessible: allow for a clearance of 200 mm around the housing.
- The air tightness class will be maintained if the damper is installed according to the installation manual.
- Rf-t fire dampers are always tested in standardised constructions according to EN 1366-2. The achieved results are valid for similar supporting constructions with a fire resistance, thickness and density equal or superior to the supporting construction used during the test.
- If the wall thickness exceeds the minimum thickness specified in our installation instructions, the following conditions apply to the sealing depth:
  - For flexible walls and sandwich panel system walls, the seal must always be applied over the full depth of the wall.
  - With rigid walls, rigid floors and plaster block walls, the minimum sealing depth as indicated in our installation instructions (often equal to the minimum wall thickness) is sufficient. Apply the seal at the height of the damper blade (from the wall limit indication).
- When installing a fire damper in a flexible metal stud wall, some installation methods do not require reinforcing profiles around the wall opening from a fire protection point of view (see below). Always follow the general instructions of the manufacturer of these wall systems when building this type of wall.
- The damper must remain accessible for inspection and maintenance.
- Schedule at least 2 visual checks each year.

	TEST	
2021	<input checked="" type="checkbox"/>	<input checked="" type="checkbox"/>
2022	<input checked="" type="checkbox"/>	<input type="checkbox"/>
2023	<input type="checkbox"/>	<input type="checkbox"/>
2024	<input type="checkbox"/>	<input type="checkbox"/>
2025	<input type="checkbox"/>	<input type="checkbox"/>

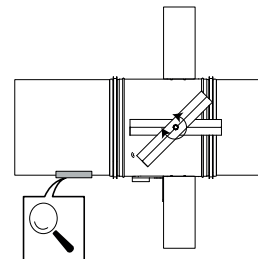

## Installation at a minimal distance from another damper or from an adjacent supporting construction

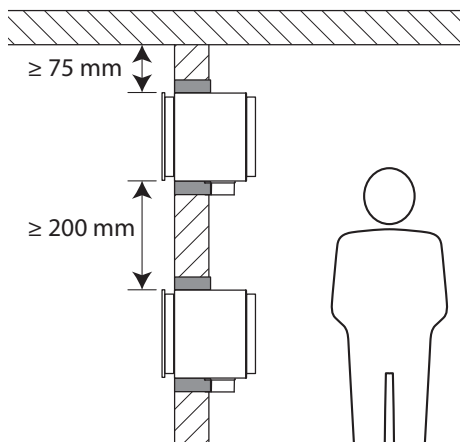
**1**

### 1. Principle

According to the European test standard, a fire damper must be installed at a minimum distance of 75 mm from an adjacent wall and 200 mm from another damper, unless the solution was tested at a shorter distance.

## Installation in rigid wall

The product was tested and approved in:

Range	Wall type	Sealing	Classification
$200 \times 200 \text{ mm} \leq \text{CU2-15} \leq 1200 \times 800 \text{ mm}$	Rigid wall	Reinforced concrete $\geq 110 \text{ mm}$	Mortar
			El 120 (v <sub>e</sub> i ↔ o) S - (1500 Pa)

1

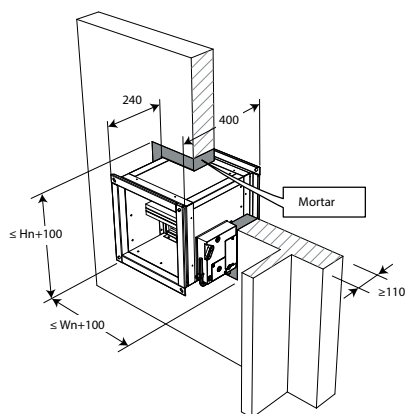

2

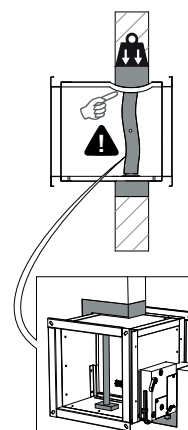

3

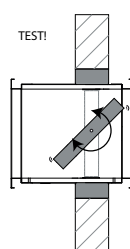

## Maintenance

- No specific maintenance required.
- Schedule at least 2 visual checks each year.
- Remove dust and all other particles before use.
- Follow local maintenance regulations (i.e. BS9999 Annex V; NF S 61-933) and EN13306.
- Read the maintenance instructions on our website:  
[https://www.rft.eu/assets//PIM/DOCUMENTS/BROCHURE%20KITS/BRO\\_K139\\_MAINTENANCE\\_C.pdf](https://www.rft.eu/assets//PIM/DOCUMENTS/BROCHURE%20KITS/BRO_K139_MAINTENANCE_C.pdf)
- Use the damper at up to 95% humidity, non-condensing.
- The fire damper can be cleaned with a dry or slightly damp cloth. It is forbidden to use abrasive cleaners or mechanical cleaning techniques (brush).

## Operation and mechanisms



### CFTH Mechanism with fusible link

The unlocking mechanism CFTH automatically unlatches the damper blade when the temperature in the duct rises above 72°C. The damper can also be unlocked and reset manually.

1. unlocking button
2. resetting handle
3. cable entrance

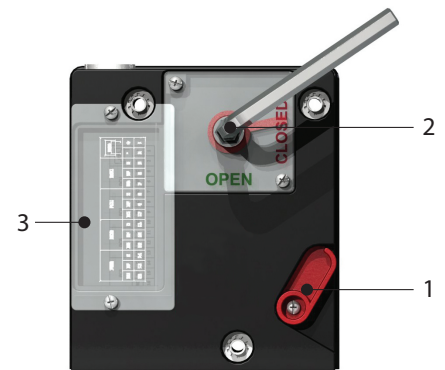

### Options - at the time of order

<b>FCU</b>	Limit switch 'closed'
<b>FDCU</b>	Unipolar limit switch 'open/closed'
<b>FDCB</b>	Bipolar auxiliary limit switch 'open/closed'

### Unlocking

- **manual unlocking:** use the unlocking button (1).
- **automatic unlocking:** when the fusible link melts at 72° C.
- **remote unlocking:** n/a

### Resetting

- **manual resetting:** use the enclosed Hex key and turn clockwise(2).
- **motorised resetting:** n/a

### Caution:

- ▲ The mechanism may never be tested on its own, without being attached to the damper. Such a test might damage the mechanism or the operator might be injured.



## ONE Spring return actuator for remote control

The spring-return actuator ONE is designed to easily operate Rf-t fire dampers of all sizes, automatically or remotely. Six models are available, 24 or 230 volt, with FDCU or FDCB position switches; and optionally with plug (ST).

1. unlocking button
2. blade position indicator
3. LED
4. battery compartment to reset motor

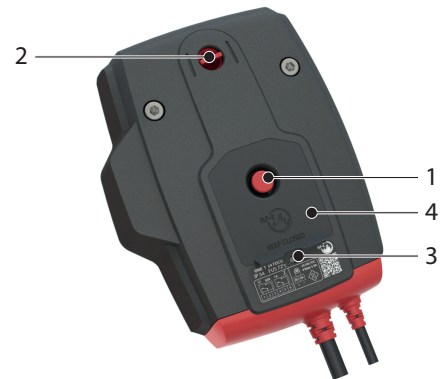

### Unlocking

- **manual unlocking:** shortly press the unlocking button (1) once.
- **automatic unlocking:** the fusible link reacts as soon as the temperature in the duct reaches 72°C.
- **remote unlocking:** by interrupting the power supply.

### Resetting

- **manual resetting:** open the battery compartment (4) and press a 9V battery against the contact springs. Hold this position until the LED (3) emits a continuous light.  
Check whether the indicator (2) shows that the damper blade is in the open position.  
Remove the battery, the LED fades away.  
Close the battery compartment.
- **motorised resetting:** switch off the power supply for at least 5 sec. Power the actuator (respect the prescribed voltage) for at least 75 sec. The resetting stops automatically when the end of range is reached (damper open).

### Caution:

- ⚠ If the LED (3) flickers fast (3x/sec.), the battery is discharged: use a new battery.
- ⚠ If the LED (3) flickers slowly (1x/sec), the resetting is in progress.
- ⚠ If the LED (3) is continuously on, the resetting is complete and the motor is powered.
- ⚠ If the actuator detects voltage on the power cable, a brief contact of the battery is enough to start the resetting process.
- ⚠ The power supply of this actuator cannot be individually replaced. If the cable is damaged, the whole unit must be discarded and replaced.
- ⚠ The housing of the mechanism contains a temperature sensor. When the temperature in the housing exceeds 72°C, the mechanism unlocks. The LED flashes twice per second. When the temperature drops below 72°C, the mechanism can only be reset in a motorised manner after a manual reset (with a battery).
- ⚠ The end of range switches need 1 second after operation to adopt a stable position.
- ⚠ Make sure the thermal trigger device is present in the actuator. The actuator might not function properly if this is not the case.

	prod. < 1/7/2015				prod. ≥ 1/7/2015			
	CR60(1s) CR120	CU-LT CU-LT-1s	CR2≤400 CU2≤1200	CR2>400 CU2>1200	CR60(1s) CR120(1s)	CU-LT CU-LT-1s	CR2≤400 CU2≤1200	CR2>400 CU2>1200
Kit ONE	●	●	●		●	●	●	●



### ONE-X Spring return actuator with integrated communication module.

The ONE-X is a spring return actuator with integrated communication module designed to simply operate Rf-t fire dampers of all sizes, automatically or remotely. The ONE-X is available in two versions: 24 V and 230 V.

1. unlocking button
2. blade position indicator
3. LED red: status
4. battery compartment
5. LED blue: communication
6. LED orange: error message
7. supply
8. bus cable

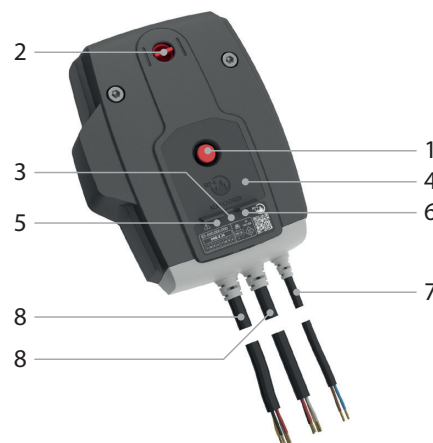

### Unlocking

- **manual unlocking:** shortly press the unlocking button (1) once.
- **automatic unlocking:** the fusible link reacts as soon as the temperature in the duct reaches 72°C.
- **remote unlocking:** via ZENiX controller

### Resetting

- **manual resetting:** Open the battery compartment (4) and press a 9V battery against the contact springs. Hold this position until the red LED (3) emits a continuous light. Control whether the indicator (2) indicates that the damper blade is open. Remove the battery. Close the battery compartment.
- **motorised resetting:** via ZENiX controller. By applying voltage during first use.

### Caution:

- ⚠ If the ONE-X detects voltage on the power cable, a brief contact of the battery is enough to start the resetting process, provided the ZENiX controller has sent the damper to open position or the ONE-X is being operated for the first time.
- ⚠ The power supply of this actuator cannot be individually replaced. If the cable is damaged, the whole unit must be discarded and replaced.
- ⚠ The housing of the mechanism contains a temperature sensor. When the temperature in the housing exceeds 72°C, the mechanism unlocks. The LED flashes twice per second. When the temperature drops below 72°C, the mechanism can only be reset in a motorised manner after a manual reset (with a battery).
- ⚠ The end of range switches need 1 second after operation to adopt a stable position.

### Safety regulations:

- ⚠ Do not use the ONE-X for any application other than the specified applications, in particular not in aircraft or other airborne vehicles.
- ⚠ The company that purchases and/or installs the ONE-X is fully responsible for the correct operation of the entire system. Only authorised specialists may perform the installation. All rules and regulations, including statutory regulations, must be observed during installation.
- ⚠ This device contains electrical or electronic components and must not be disposed of as household waste. All locally applicable regulations and requirements must be strictly observed.





## BFL(T) Remotely controlled spring return actuator

The spring return actuator BFL(T) is especially designed to operate fire dampers remotely. The BFL(T) variant is intended for fire dampers with smaller dimensions (CR60, CR120, CR2 with  $\varnothing \leq 400$  mm, CRS60 with  $\varnothing \leq 315$  mm, CU2 / CU2-15 / CU4 with B+H  $\leq 1200$  mm or for CU-LT and CU-LT-1s). For Markage FD with H = 200 mm or H = 2200 mm (in combination with BFT motor).

1. locking button
2. plug (ST)
3. access for manual resetting
4. thermo-electric tripping device (T)



### Options - at the time of order

**SN2 BFL/BFN** Auxiliary limit switch 'open/closed'

### Unlocking

- **manual unlocking:** place the locking button on "unlock". (In case of BFLT: the damper can alternatively be unlocked by pushing the "test" button on the thermo-electric fuse)
- **automatic unlocking:** the thermo-electric fuse reacts as soon as the temperature reaches 72°C (type BFLT).
- **remote unlocking:** by interrupting the power supply.

#### Caution:

⚠ The thermo-electric fuse will not move the damper into its safety position (when the temperature reaches 72°C) if the motor is not powered.

### Resetting

- **manual resetting:** turn the enclosed handle anti-clockwise. To block the motor, place the locking button on "lock"
- **motorised resetting:** switch off the power supply for at least 10 seconds. Supply the actuator (respect the prescribed voltage) for at least 75 seconds. The resetting stops automatically when the end of range is reached (damper open) - it takes about 60 seconds to reset the damper - or when the power supply is interrupted.

#### Caution:

- ⚠ Do not use a drill or powered screwdriver.
- ⚠ Stop as soon as the motor is completely rearmed (end of range).

	prod. < 1/7/2015				prod. ≥ 1/7/2015			
	CR60(1s) CR120	CU-LT CU-LT-1s	CR2≤400 CU2≤1200	CR2>400 CU2>1200	CR60(1s) CR120 (1s)	CU-LT CU-LT-1s	CR2≤400 CU2≤1200	CR2>400 CU2>1200
Kit BFL					●	●	●	
Kit BFN	●	●	●					●
Kit BF				●				



## BFN(T) Remotely controlled spring return actuator

The spring return actuator BFN(T) is especially designed to operate fire dampers remotely. The BFN(T) variant is intended for fire dampers with large dimensions (CRE60, CR2 with  $\varnothing > 400$  mm, CRS60 with  $\varnothing > 315$  mm or CU2, CU2-15, CU4 with B+H  $> 1200$  mm. For Markage FD with H of 400 and 600 mm or with H = 1200 mm (2 pcs) and with H = 2400 mm (in combination with BFT motor).

1. locking button
2. plug (ST)
3. access for manual resetting
4. thermo-electric tripping device (T)

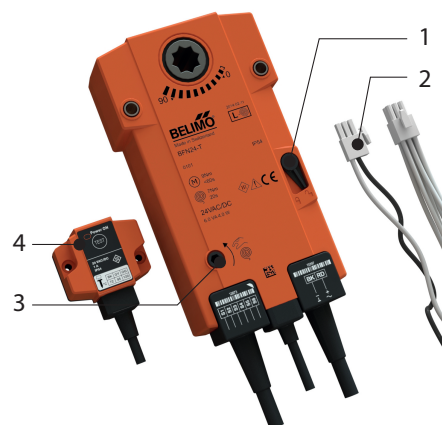

### Options - at the time of order

**SN2 BFL/BFN** Auxiliary limit switch 'open/closed'

### Unlocking

- **manual unlocking:** place the locking button on "unlock". (In case of BFNT: the damper can alternatively be unlocked by pushing the "test" button on the thermo-electric fuse)
- **automatic unlocking:** the thermo-electric fuse reacts as soon as the temperature reaches 72°C (type BFNT).
- **remote unlocking:** by interrupting the power supply.

#### Caution:

- ⚠ The thermo-electric fuse will not move the damper into its safety position (when the temperature reaches 72°C) if the motor is not powered.

### Resetting

- **manual resetting:** turn the enclosed handle anti-clockwise. To block the motor, place the locking button on "lock"
- **motorised resetting:** switch off the power supply for at least 10 seconds. Supply the actuator (respect the prescribed voltage) for at least 75 seconds. The resetting stops automatically when the end of range is reached (damper open) - it takes about 60 seconds to reset the damper - or when the power supply is interrupted.

#### Caution:

- ⚠ Do not use a drill or powered screwdriver.
- ⚠ Stop as soon as the motor is completely rearmed (end of range).

	prod. < 1/7/2015				prod. ≥ 1/7/2015			
	CR60(1s) CR120	CU-LT CU-LT-1s	CR2≤400 CU2≤1200	CR2>400 CU2>1200	CR60(1s) CR120 (1s)	CU-LT CU-LT-1s	CR2≤400 CU2≤1200	CR2>400 CU2>1200
Kit BFL					●	●	●	
Kit BFN	●	●	●					●
Kit BF				●				

## Electrical connection

### CFTH

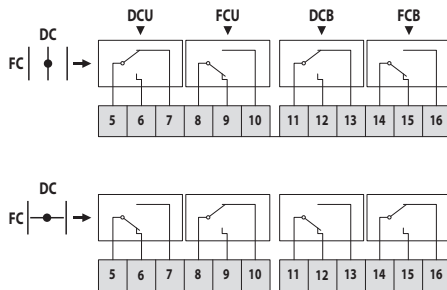

DC: Switch open position fire damper  
 FC: Switch closed position fire damper

### ONE

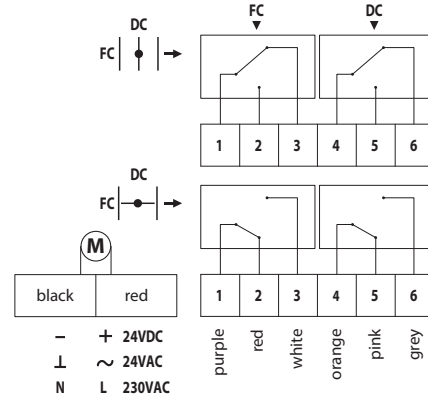

DC: Switch open position fire damper  
 FC: Switch closed position fire damper

### ONE-X

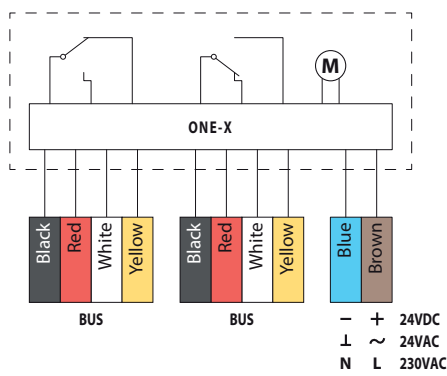

### BFL(T)

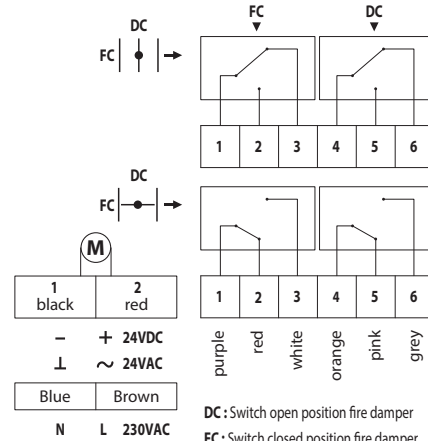

DC: Switch open position fire damper  
 FC: Switch closed position fire damper

### BFN(T)

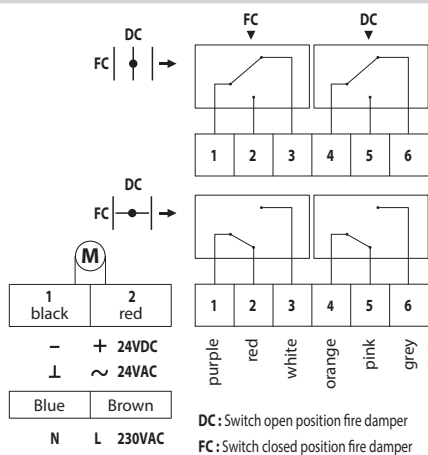

DC: Switch open position fire damper  
 FC: Switch closed position fire damper

MEC	Nominal voltage motor	Nominal voltage magnet	Power consumption (stand-by)	Power consumption (operating)	Standard switches	Resetting time motor	Running time spring
CFTH	N/A	N/A	N/A	N/A	1mA...6A, DC 5V...AC 250V	N/A	1 s
ONET 24 FDCU	24 V AC/DC (-10/+20%)	N/A	0,28 W	4,2 W	1mA...1A 60V	< 75 s (cabled) / < 85 s (battery)	< 30 s
ONET 24 FDCU ST	24 V AC/DC (-10/+20%)	N/A	0,28 W	4,2 W	1mA...1A 60V	< 75 s (cabled) / < 85 s (battery)	< 30 s
ONET 230 FDCU	230 V AC (-15/+15%)	N/A	0,57 W	4,2 W	1mA...100mA 230V	< 75 s (cabled) / < 85 s (battery)	< 30 s
ONET 230 FDCU ST	230 V AC (-15/+15%)	N/A	0,57 W	4,2 W	1mA...100mA 230V	< 75 s (cabled) / < 85 s (battery)	< 30 s
ONET 24 FDCB	24 V AC/DC (-10/+20%)	N/A	0,28 W	4,2 W	1mA...1A 60V	< 75 s (cabled) / < 85 s (battery)	< 30 s
ONET 230 FDCB	230 V AC (-15/+15%)	N/A	0,57 W	4,2 W	1mA...1A 60V	< 75 s (cabled) / < 85 s (battery)	< 30 s
ONE-X 24	24 V AC/DC (-10/+20%)	N/A	0,28 W	4,2 W		< 75 s (cabled) / < 85 s (battery)	< 30 s
ONE-X 230	230 V AC (-15/+15%)	N/A	0,57 W	4,2 W		< 75 s (cabled) / < 85 s (battery)	< 30 s
BFL24	24 V AC/DC	N/A	0,7 W	2,5 W	1mA...3A, AC 250V	< 60 s	20 s
BFL24-ST	24 V AC/DC	N/A	0,7 W	2,5 W	1mA...3A, AC 250V	< 60 s	20 s
BFL230	230 V AC	N/A	0,9 W	3 W	1mA...3A, AC 250V	< 60 s	20 s
BFLT24	24 V AC/DC	N/A	0,8 W	2,5 W	1mA...3A, AC 250V	< 60 s	20 s
BFLT24-ST	24 V AC/DC	N/A	0,8 W	2,5 W	1mA...3A, AC 250V	< 60 s	20 s
BFLT230	230 V AC	N/A	1,1 W	3,5 W	1mA...3A, AC 250V	< 60 s	20 s
BFLT230-ST	230 V AC	N/A	1,1 W	3,5 W	1mA...3A, AC 250V	< 60 s	20 s
BFN24	24 V AC/DC	N/A	1,4 W	4 W	1mA...3A, AC 250V	< 60 s	20 s
BFN24-ST	24 V AC/DC	N/A	1,4 W	4 W	1mA...3A, AC 250V	< 60 s	20 s
BFN230	230 V AC	N/A	2 W	4,5 W	1mA...3A, AC 250V	< 60 s	20 s
BFNT24	24 V AC/DC	N/A	1,4 W	4 W	1mA...3A, AC 250V	< 60 s	20 s
BFNT24-ST	24 V AC/DC	N/A	1,4 W	4 W	1mA...3A, AC 250V	< 60 s	20 s
BFNT230	230 V AC	N/A	2,1 W	5 W	1mA...3A, AC 250V	< 60 s	20 s
BFNT230-ST	230 V AC	N/A	2,1 W	5 W	1mA...3A, AC 250V	< 60 s	20 s

MEC	Noise level motor	Noise level spring	Cable supply / control	Cable auxiliary switch	Protection class
CFTH	N/A	N/A			IP 42
ONET 24 FDCU	< 64 dB (A)	< 67 dB (A)	1 m, 2 x 0.75 mm <sup>2</sup> (halogen-free)	1 m, 6 x 0.75 mm <sup>2</sup> (halogen-free)	IP 54
ONET 24 FDCU ST	< 64 dB (A)	< 67 dB (A)	1 m, 2 x 0.75 mm <sup>2</sup> (halogen-free)	1 m, 6 x 0.75 mm <sup>2</sup> (halogen-free)	IP 54
ONET 230 FDCU	< 64 dB (A)	< 67 dB (A)	1 m, 2 x 0.75 mm <sup>2</sup> (halogen-free)	1 m, 6 x 0.75 mm <sup>2</sup> (halogen-free)	IP 54
ONET 230 FDCU ST	< 64 dB (A)	< 67 dB (A)	1 m, 2 x 0.75 mm <sup>2</sup> (halogen-free)	1 m, 6 x 0.75 mm <sup>2</sup> (halogen-free)	IP 54
ONET 24 FDCB	< 64 dB (A)	< 67 dB (A)	1 m, 2 x 0.75 mm <sup>2</sup> (halogen-free)	(2x) 1 m, 6 x 0,75 mm <sup>2</sup> (halogen-free)	IP 54
ONET 230 FDCB	< 64 dB (A)	< 67 dB (A)	1 m, 2 x 0.75 mm <sup>2</sup> (halogen-free)	(2x) 1 m, 6 x 0,75 mm <sup>2</sup> (halogen-free)	IP 54
ONE-X 24	< 64 dB (A)	< 67 dB (A)	1 m, 2 x 0.75 mm <sup>2</sup> (halogen-free)	bus cable: (2x) 1 m, 4 x 0,75 mm <sup>2</sup> (halogen-free)	IP 54
ONE-X 230	< 64 dB (A)	< 67 dB (A)	1 m, 2 x 0.75 mm <sup>2</sup> (halogen-free)	bus cable: (2x) 1 m, 4 x 0,75 mm <sup>2</sup> (halogen-free)	IP 54
BFL24	< 43 dB (A)	< 62 dB (A)	1 m, 2 x 0.75 mm <sup>2</sup> (halogen-free)	1 m, 6 x 0.75 mm <sup>2</sup> (halogen-free)	IP 54
BFL24-ST	< 43 dB (A)	< 62 dB (A)	1 m, 2 x 0.75 mm <sup>2</sup> (halogen-free)	1 m, 6 x 0.75 mm <sup>2</sup> (halogen-free)	IP 54
BFL230	< 43 dB (A)	< 62 dB (A)	1 m, 2 x 0.75 mm <sup>2</sup> (halogen-free)	1 m, 6 x 0.75 mm <sup>2</sup> (halogen-free)	IP 54
BFLT24	< 43 dB (A)	< 62 dB (A)	1 m, 2 x 0.75 mm <sup>2</sup> (halogen-free)	1 m, 6 x 0.75 mm <sup>2</sup> (halogen-free)	IP 54
BFLT24-ST	< 43 dB (A)	< 62 dB (A)	1 m, 2 x 0.75 mm <sup>2</sup> (halogen-free)	1 m, 6 x 0.75 mm <sup>2</sup> (halogen-free)	IP 54
BFLT230	< 43 dB (A)	< 62 dB (A)	1 m, 2 x 0.75 mm <sup>2</sup> (halogen-free)	1 m, 6 x 0.75 mm <sup>2</sup> (halogen-free)	IP 54
BFLT230-ST	< 43 dB (A)	< 62 dB (A)	1 m, 2 x 0.75 mm <sup>2</sup> (halogen-free)	1 m, 6 x 0.75 mm <sup>2</sup> (halogen-free)	IP 54
BFN24	≤ 55 dB (A)	ca. 67 dB (A)	1 m, 2 x 0.75 mm <sup>2</sup> (halogen-free)	1 m, 6 x 0.75 mm <sup>2</sup> (halogen-free)	IP 54
BFN24-ST	≤ 55 dB (A)	ca. 67 dB (A)	1 m, 2 x 0.75 mm <sup>2</sup> (halogen-free)	1 m, 6 x 0.75 mm <sup>2</sup> (halogen-free)	IP 54
BFN230	≤ 55 dB (A)	ca. 67 dB (A)	1 m, 2 x 0.75 mm <sup>2</sup> (halogen-free)	1 m, 6 x 0.75 mm <sup>2</sup> (halogen-free)	IP 54
BFNT24	≤ 55 dB (A)	ca. 67 dB (A)	1 m, 2 x 0.75 mm <sup>2</sup> (halogen-free)	1 m, 6 x 0.75 mm <sup>2</sup> (halogen-free)	IP 54
BFNT24-ST	≤ 55 dB (A)	ca. 67 dB (A)	1 m, 2 x 0.75 mm <sup>2</sup> (halogen-free)	1 m, 6 x 0.75 mm <sup>2</sup> (halogen-free)	IP 54
BFNT230	≤ 55 dB (A)	ca. 67 dB (A)	1 m, 2 x 0.75 mm <sup>2</sup> (halogen-free)	1 m, 6 x 0.75 mm <sup>2</sup> (halogen-free)	IP 54
BFNT230-ST	≤ 55 dB (A)	ca. 67 dB (A)	1 m, 2 x 0.75 mm <sup>2</sup> (halogen-free)	1 m, 6 x 0.75 mm <sup>2</sup> (halogen-free)	IP 54

## Weights

## CU2-15 + CFTH

Hn\Wn (mm)		200	250	300	350	400	450	500	550	600	650	700	750	800	850	900
200	kg	11,1	12,3	13,5	14,8	16,0	17,2	18,4	19,7	20,9	22,1	23,3	24,5	25,8	27,0	28,2
250	kg	12,3	13,7	15,0	16,3	17,7	19,0	20,4	21,7	23,1	24,4	25,7	27,1	28,4	29,8	31,1
300	kg	13,5	15,0	16,5	17,9	19,4	20,9	22,3	23,8	25,2	26,7	28,2	29,6	31,1	32,5	34,0
350	kg	14,8	16,3	17,9	19,5	21,1	22,7	24,3	25,8	27,4	29,0	30,6	32,2	33,7	35,3	36,9
400	kg	16,0	17,7	19,4	21,1	22,8	24,5	26,2	27,9	29,6	31,3	33,0	34,7	36,4	38,1	39,8
450	kg	17,2	19,0	20,9	22,7	24,5	26,3	28,1	30,0	31,8	33,6	35,4	37,2	39,1	40,9	42,7
500	kg	18,4	20,4	22,3	24,3	26,2	28,1	30,1	32,0	34,0	35,9	37,8	39,8	41,7	43,7	45,6
550	kg	19,7	21,7	23,8	25,8	27,9	30,0	32,0	34,1	36,1	38,2	40,3	42,3	44,4	46,4	48,5
600	kg	20,9	23,1	25,2	27,4	29,6	31,8	34,0	36,1	38,3	40,5	42,7	44,9	47,0	49,2	51,4
650	kg	22,1	24,4	26,7	29,0	31,3	33,6	35,9	38,2	40,5	42,8	45,1	47,4	49,7	52,0	54,3
700	kg	23,3	25,7	28,2	30,6	33,0	35,4	37,8	40,3	42,7	45,1	47,5	49,9	52,3	54,8	57,2
750	kg	24,5	27,1	29,6	32,2	34,7	37,2	39,8	42,3	44,9	47,4	49,9	52,5	55,0	57,5	60,1
800	kg	25,8	28,4	31,1	33,7	36,4	39,1	41,7	44,4	47,0	49,7	52,3	55,0	57,7	60,3	63,0

Hn\Wn (mm)		950	1000	1050	1100	1150	1200									
200	kg	29,4	30,7	31,9	33,1	34,3	35,5									
250	kg	32,5	33,8	35,1	36,5	37,8	39,2									
300	kg	35,5	36,9	38,4	39,9	41,3	42,8									
350	kg	38,5	40,1	41,7	43,2	44,8	46,4									
400	kg	41,5	43,2	44,9	46,6	48,3	50,0									
450	kg	44,5	46,3	48,2	50,0	51,8	53,6									
500	kg	47,5	49,5	51,4	53,4	55,3	57,2									
550	kg	50,6	52,6	54,7	56,7	58,8	60,9									
600	kg	53,6	55,8	57,9	60,1	62,3	64,5									
650	kg	56,6	58,9	61,2	63,5	65,8	68,1									
700	kg	59,6	62,0	64,4	66,9	69,3	71,7									
750	kg	62,6	65,2	67,7	70,2	72,8	75,3									
800	kg	65,6	68,3	71,0	73,6	76,3	78,9									

## CU2-15 + ONE

Hn\Wn (mm)		200	250	300	350	400	450	500	550	600	650	700	750	800	850	900
200	kg	11,9	13,1	14,3	15,6	16,8	18,0	19,2	20,5	21,7	22,9	24,1	25,3	26,6	27,8	29,0
250	kg	13,1	14,5	15,8	17,1	18,5	19,8	21,2	22,5	23,9	25,2	26,5	27,9	29,2	30,6	31,9
300	kg	14,3	15,8	17,3	18,7	20,2	21,7	23,1	24,6	26,0	27,5	29,0	30,4	31,9	33,3	34,8
350	kg	15,6	17,1	18,7	20,3	21,9	23,5	25,1	26,6	28,2	29,8	31,4	33,0	34,5	36,1	37,7
400	kg	16,8	18,5	20,2	21,9	23,6	25,3	27,0	28,7	30,4	32,1	33,8	35,5	37,2	38,9	40,6
450	kg	18,0	19,8	21,7	23,5	25,3	27,1	28,9	30,8	32,6	34,4	36,2	38,0	39,9	41,7	43,5
500	kg	19,2	21,2	23,1	25,1	27,0	28,9	30,9	32,8	34,8	36,7	38,6	40,6	42,5	44,5	46,4
550	kg	20,5	22,5	24,6	26,6	28,7	30,8	32,8	34,9	36,9	39,0	41,1	43,1	45,2	47,2	49,3
600	kg	21,7	23,9	26,0	28,2	30,4	32,6	34,8	36,9	39,1	41,3	43,5	45,7	47,8	50,0	52,2
650	kg	22,9	25,2	27,5	29,8	32,1	34,4	36,7	39,0	41,3	43,6	45,9	48,2	50,5	52,8	55,1
700	kg	24,1	26,5	29,0	31,4	33,8	36,2	38,6	41,1	43,5	45,9	48,3	50,7	53,1	55,6	58,0
750	kg	25,3	27,9	30,4	33,0	35,5	38,0	40,6	43,1	45,7	48,2	50,7	53,3	55,8	58,3	60,9
800	kg	26,6	29,2	31,9	34,5	37,2	39,9	42,5	45,2	47,8	50,5	53,1	55,8	58,5	61,1	63,8



## CU2-15 + BFN

Hn\Wn (mm)		200	250	300	350	400	450	500	550	600	650	700	750	800	850	900
200	kg	-	-	-	-	-	-	-	-	-	-	-	-	-	-	-
250	kg	-	-	-	-	-	-	-	-	-	-	-	-	-	-	-
300	kg	-	-	-	-	-	-	-	-	-	-	-	-	-	-	-
350	kg	-	-	-	-	-	-	-	-	-	-	-	-	-	-	37,3
400	kg	-	-	-	-	-	-	-	-	-	-	-	-	-	38,5	40,2
450	kg	-	-	-	-	-	-	-	-	-	-	-	-	39,4	41,2	43,1
500	kg	-	-	-	-	-	-	-	-	-	-	-	40,1	42,1	44,0	45,9
550	kg	-	-	-	-	-	-	-	-	-	-	40,6	42,7	44,7	46,8	48,8
600	kg	-	-	-	-	-	-	-	-	-	40,8	43,0	45,2	47,4	49,6	51,7
650	kg	-	-	-	-	-	-	-	-	40,8	43,1	45,4	47,7	50,0	52,3	54,6
700	kg	-	-	-	-	-	-	-	40,6	43,0	45,4	47,9	50,3	52,7	55,1	57,5
750	kg	-	-	-	-	-	-	40,1	42,7	45,2	47,7	50,3	52,8	55,4	57,9	60,4
800	kg	-	-	-	-	-	39,4	42,1	44,7	47,4	50,0	52,7	55,4	58,0	60,7	63,3

Hn\Wn (mm)		950	1000	1050	1100	1150	1200									
200	kg	-	-	32,2	33,5	34,7	35,9									
250	kg	-	34,1	35,5	36,8	38,2	39,5									
300	kg	35,8	37,3	38,7	40,2	41,7	43,1									
350	kg	38,8	40,4	42,0	43,6	45,2	46,7									
400	kg	41,9	43,6	45,3	47,0	48,7	50,4									
450	kg	44,9	46,7	48,5	50,3	52,2	54,0									
500	kg	47,9	49,8	51,8	53,7	55,6	57,6									
550	kg	50,9	53,0	55,0	57,1	59,1	61,2									
600	kg	53,9	56,1	58,3	60,5	62,6	64,8									
650	kg	56,9	59,2	61,5	63,8	66,1	68,4									
700	kg	60,0	62,4	64,8	67,2	69,6	72,1									
750	kg	63,0	65,5	68,1	70,6	73,1	75,7									
800	kg	66,0	68,6	71,3	74,0	76,6	79,3									

## CU2-15 + BFNT

Hn\Wn (mm)		200	250	300	350	400	450	500	550	600	650	700	750	800	850	900
200	kg	-	-	-	-	-	-	-	-	-	-	-	-	-	-	-
250	kg	-	-	-	-	-	-	-	-	-	-	-	-	-	-	-
300	kg	-	-	-	-	-	-	-	-	-	-	-	-	-	-	-
350	kg	-	-	-	-	-	-	-	-	-	-	-	-	-	-	37,4
400	kg	-	-	-	-	-	-	-	-	-	-	-	-	-	38,6	40,3
450	kg	-	-	-	-	-	-	-	-	-	-	-	-	39,5	41,3	43,2
500	kg	-	-	-	-	-	-	-	-	-	-	-	40,2	42,2	44,1	46,0
550	kg	-	-	-	-	-	-	-	-	-	-	40,7	42,8	44,8	46,9	48,9
600	kg	-	-	-	-	-	-	-	-	-	40,9	43,1	45,3	47,5	49,7	51,8
650	kg	-	-	-	-	-	-	-	-	40,9	43,2	45,5	47,8	50,1	52,4	54,7
700	kg	-	-	-	-	-	-	-	40,7	43,1	45,5	48,0	50,4	52,8	55,2	57,6
750	kg	-	-	-	-	-	-	40,2	42,8	45,3	47,8	50,4	52,9	55,5	58,0	60,5
800	kg	-	-	-	-	-	39,5	42,2	44,8	47,5	50,1	52,8	55,5	58,1	60,8	63,4





Example

Data

Hn = 400 mm, Wn = 500 mm, v = 4 m/s

Calculation

$$\Delta p = 0.70 * (4 \text{ m/s})^2 * 0.6 = 6.72 \text{ Pa}$$

CU2-15

Hn\Wn [mm]		200	250	300	350	400	450	500	550	600	650	700
200	Sn [m <sup>2</sup> ]	0,0128	0,0173	0,0217	0,0262	0,0306	0,0351	0,0395	0,0440	0,0484	0,0529	0,0573
	Sn [%]	34,05	36,48	38,07	39,21	40,05	40,71	41,23	41,66	42,01	42,31	42,57
250	Sn [m <sup>2</sup> ]	0,0200	0,0270	0,0339	0,0409	0,0478	0,0548	0,0617	0,0687	0,0756	0,0826	0,0895
	Sn [%]	42,28	45,29	47,28	48,69	49,74	50,55	51,20	51,73	52,17	52,54	52,86
300	Sn [m <sup>2</sup> ]	0,0272	0,0367	0,0461	0,0556	0,0650	0,0745	0,0839	0,0934	0,1028	0,1123	0,1217
	Sn [%]	47,72	51,11	53,35	54,94	56,13	57,05	57,78	58,38	58,87	59,29	59,65
350	Sn [m <sup>2</sup> ]	0,0344	0,0464	0,0583	0,0703	0,0822	0,0942	0,1061	0,1181	0,1300	0,1420	0,1539
	Sn [%]	51,57	55,24	57,66	59,38	60,66	61,65	62,44	63,09	63,63	64,08	64,47
400	Sn [m <sup>2</sup> ]	0,0416	0,0561	0,0705	0,0850	0,0994	0,1139	0,1283	0,1428	0,1572	0,1717	0,1861
	Sn [%]	54,45	58,32	60,88	62,69	64,04	65,09	65,93	66,61	67,18	67,66	68,07
450	Sn [m <sup>2</sup> ]	0,0488	0,0658	0,0827	0,0997	0,1166	0,1336	0,1505	0,1675	0,1844	0,2014	0,2183
	Sn [%]	56,67	60,71	63,37	65,25	66,66	67,75	68,62	69,33	69,92	70,42	70,85
500	Sn [m <sup>2</sup> ]	0,0546	0,0735	0,0925	0,1114	0,1304	0,1493	0,1683	0,1872	0,2062	0,2251	0,2441
	Sn [%]	56,95	61,00	63,67	65,57	66,98	68,08	68,96	69,67	70,26	70,76	71,19
550	Sn [m <sup>2</sup> ]	0,0618	0,0832	0,1047	0,1261	0,1476	0,1690	0,1905	0,2119	0,2334	0,2548	0,2763
	Sn [%]	58,54	62,70	65,45	67,40	68,85	69,98	70,88	71,61	72,22	72,74	73,18
600	Sn [m <sup>2</sup> ]	0,0690	0,0929	0,1169	0,1408	0,1648	0,1887	0,2127	0,2366	0,2606	0,2845	0,3085
	Sn [%]	59,86	64,12	66,93	68,92	70,41	71,56	72,48	73,23	73,85	74,38	74,83
650	Sn [m <sup>2</sup> ]	0,0762	0,1026	0,1291	0,1555	0,1820	0,2084	0,2349	0,2613	0,2878	0,3142	0,3407
	Sn [%]	60,97	65,31	68,17	70,20	71,72	72,89	73,83	74,59	75,23	75,77	76,22
700	Sn [m <sup>2</sup> ]	0,0834	0,1123	0,1413	0,1702	0,1992	0,2281	0,2571	0,2860	0,3150	0,3439	0,3729
	Sn [%]	61,93	66,33	69,24	71,30	72,84	74,03	74,99	75,76	76,41	76,95	77,42
750	Sn [m <sup>2</sup> ]	0,0906	0,1220	0,1535	0,1849	0,2164	0,2478	0,2793	0,3107	0,3422	0,3736	0,4051
	Sn [%]	62,75	67,22	70,16	72,25	73,81	75,02	75,99	76,77	77,43	77,98	78,45
800	Sn [m <sup>2</sup> ]	0,0978	0,1317	0,1657	0,1996	0,2336	0,2675	0,3015	0,3354	0,3694	0,4033	0,4373
	Sn [%]	63,48	67,99	70,97	73,09	74,66	75,89	76,86	77,66	78,32	78,88	79,36

Hn\Wn [mm]		750	800	850	900	950	1000	1050	1100	1150	1200
200	Sn [m <sup>2</sup> ]	0,0618	0,0662	0,0707	0,0751	0,0796	0,0840	0,0885	0,0929	0,0974	0,1018
	Sn [%]	42,79	42,99	43,16	43,31	43,45	43,57	43,68	43,78	43,87	43,96
250	Sn [m <sup>2</sup> ]	0,0965	0,1034	0,1104	0,1173	0,1243	0,1312	0,1382	0,1451	0,1521	0,1590
	Sn [%]	53,14	53,38	53,59	53,78	53,95	54,10	54,24	54,36	54,48	54,58
300	Sn [m <sup>2</sup> ]	0,1312	0,1406	0,1501	0,1595	0,1690	0,1784	0,1879	0,1973	0,2068	0,2162
	Sn [%]	59,97	60,24	60,48	60,69	60,88	61,05	61,21	61,35	61,48	61,59
350	Sn [m <sup>2</sup> ]	0,1659	0,1778	0,1898	0,2017	0,2137	0,2256	0,2376	0,2495	0,2615	0,2734
	Sn [%]	64,81	65,10	65,36	65,59	65,80	65,98	66,15	66,30	66,44	66,57
400	Sn [m <sup>2</sup> ]	0,2006	0,2150	0,2295	0,2439	0,2584	0,2728	0,2873	0,3017	0,3162	0,3306
	Sn [%]	68,42	68,73	69,00	69,25	69,47	69,66	69,84	70,00	70,14	70,28

Hn\Wn [mm]		750	800	850	900	950	1000	1050	1100	1150	1200	
450	Sn [m <sup>2</sup> ]	0,2353	0,2522	0,2692	0,2861	0,3031	0,3200	0,3370	0,3539	0,3709	0,3878	
	Sn [%]	71,22	71,54	71,83	72,08	72,31	72,51	72,69	72,86	73,01	73,15	
500	Sn [m <sup>2</sup> ]	0,2630	0,2820	0,3009	0,3199	0,3388	0,3578	0,3767	0,3957	0,4146	0,4336	
	Sn [%]	71,56	71,89	72,18	72,43	72,66	72,86	73,05	73,21	73,37	73,51	
550	Sn [m <sup>2</sup> ]	0,2977	0,3192	0,3406	0,3621	0,3835	0,4050	0,4264	0,4479	0,4693	0,4908	
	Sn [%]	73,56	73,89	74,19	74,45	74,68	74,89	75,08	75,26	75,41	75,56	
600	Sn [m <sup>2</sup> ]	0,3324	0,3564	0,3803	0,4043	0,4282	0,4522	0,4761	0,5001	0,5240	0,5480	
	Sn [%]	75,22	75,56	75,86	76,13	76,37	76,58	76,78	76,95	77,12	77,26	
650	Sn [m <sup>2</sup> ]	0,3671	0,3936	0,4200	0,4465	0,4729	0,4994	0,5258	0,5523	0,5787	0,6052	
	Sn [%]	76,62	76,97	77,28	77,55	77,79	78,01	78,21	78,39	78,55	78,70	
700	Sn [m <sup>2</sup> ]	0,4018	0,4308	0,4597	0,4887	0,5176	0,5466	0,5755	0,6045	0,6334	0,6624	
	Sn [%]	77,82	78,18	78,49	78,76	79,01	79,23	79,43	79,62	79,78	79,94	
750	Sn [m <sup>2</sup> ]	0,4365	0,4680	0,4994	0,5309	0,5623	0,5938	0,6252	0,6567	0,6881	0,7196	
	Sn [%]	78,86	79,22	79,53	79,81	80,07	80,29	80,49	80,68	80,85	81,00	
800	Sn [m <sup>2</sup> ]	0,4712	0,5052	0,5391	0,5731	0,6070	0,6410	0,6749	0,7089	0,7428	0,7768	
	Sn [%]	79,77	80,13	80,45	80,73	80,99	81,21	81,42	81,61	81,78	81,94	

## CU2-15L

Hn\Wn [mm]		200	250	300	350	400	450	500	550	600	650	700
200	Sn [m <sup>2</sup> ]	0,0128	0,0173	0,0217	0,0262	0,0306	0,0351	0,0395	0,0440	0,0484	0,0529	0,0573
	Sn [%]	34,05	36,48	38,07	39,21	40,05	40,71	41,23	41,66	42,01	42,31	42,57
250	Sn [m <sup>2</sup> ]	0,0200	0,0270	0,0339	0,0409	0,0478	0,0548	0,0617	0,0687	0,0756	0,0826	0,0895
	Sn [%]	42,28	45,29	47,28	48,69	49,74	50,55	51,20	51,73	52,17	52,54	52,86
300	Sn [m <sup>2</sup> ]	0,0272	0,0367	0,0461	0,0556	0,0650	0,0745	0,0839	0,0934	0,1028	0,1123	0,1217
	Sn [%]	47,72	51,11	53,35	54,94	56,13	57,05	57,78	58,38	58,87	59,29	59,65
350	Sn [m <sup>2</sup> ]	0,0344	0,0464	0,0583	0,0703	0,0822	0,0942	0,1061	0,1181	0,1300	0,1420	0,1539
	Sn [%]	51,57	55,24	57,66	59,38	60,66	61,65	62,44	63,09	63,63	64,08	64,47
400	Sn [m <sup>2</sup> ]	0,0416	0,0561	0,0705	0,0850	0,0994	0,1139	0,1283	0,1428	0,1572	0,1717	0,1861
	Sn [%]	54,45	58,32	60,88	62,69	64,04	65,09	65,93	66,61	67,18	67,66	68,07
450	Sn [m <sup>2</sup> ]	0,0488	0,0658	0,0827	0,0997	0,1166	0,1336	0,1505	0,1675	0,1844	0,2014	0,2183
	Sn [%]	56,67	60,71	63,37	65,25	66,66	67,75	68,62	69,33	69,92	70,42	70,85
500	Sn [m <sup>2</sup> ]	0,0546	0,0735	0,0925	0,1114	0,1304	0,1493	0,1683	0,1872	0,2062	0,2251	0,2441
	Sn [%]	56,95	61,00	63,67	65,57	66,98	68,08	68,96	69,67	70,26	70,76	71,19
550	Sn [m <sup>2</sup> ]	0,0618	0,0832	0,1047	0,1261	0,1476	0,1690	0,1905	0,2119	0,2334	0,2548	0,2763
	Sn [%]	58,54	62,70	65,45	67,40	68,85	69,98	70,88	71,61	72,22	72,74	73,18
600	Sn [m <sup>2</sup> ]	0,0690	0,0929	0,1169	0,1408	0,1648	0,1887	0,2127	0,2366	0,2606	0,2845	0,3085
	Sn [%]	59,86	64,12	66,93	68,92	70,41	71,56	72,48	73,23	73,85	74,38	74,83
650	Sn [m <sup>2</sup> ]	0,0762	0,1026	0,1291	0,1555	0,1820	0,2084	0,2349	0,2613	0,2878	0,3142	0,3407
	Sn [%]	60,97	65,31	68,17	70,20	71,72	72,89	73,83	74,59	75,23	75,77	76,22
700	Sn [m <sup>2</sup> ]	0,0834	0,1123	0,1413	0,1702	0,1992	0,2281	0,2571	0,2860	0,3150	0,3439	0,3729
	Sn [%]	61,93	66,33	69,24	71,30	72,84	74,03	74,99	75,76	76,41	76,95	77,42
750	Sn [m <sup>2</sup> ]	0,0906	0,1220	0,1535	0,1849	0,2164	0,2478	0,2793	0,3107	0,3422	0,3736	0,4051
	Sn [%]	62,75	67,22	70,16	72,25	73,81	75,02	75,99	76,77	77,43	77,98	78,45
800	Sn [m <sup>2</sup> ]	0,0978	0,1317	0,1657	0,1996	0,2336	0,2675	0,3015	0,3354	0,3694	0,4033	0,4373
	Sn [%]	63,48	67,99	70,97	73,09	74,66	75,89	76,86	77,66	78,32	78,88	79,36

Hn\Wn [mm]		750	800	850	900	950	1000	1050	1100	1150	1200	
<b>200</b>	Sn [m <sup>2</sup> ]	0,0618	0,0662	0,0707	0,0751	0,0796	0,0840	0,0885	0,0929	0,0974	0,1018	
	Sn [%]	42,79	42,99	43,16	43,31	43,45	43,57	43,68	43,78	43,87	43,96	
<b>250</b>	Sn [m <sup>2</sup> ]	0,0965	0,1034	0,1104	0,1173	0,1243	0,1312	0,1382	0,1451	0,1521	0,1590	
	Sn [%]	53,14	53,38	53,59	53,78	53,95	54,10	54,24	54,36	54,48	54,58	
<b>300</b>	Sn [m <sup>2</sup> ]	0,1312	0,1406	0,1501	0,1595	0,1690	0,1784	0,1879	0,1973	0,2068	0,2162	
	Sn [%]	59,97	60,24	60,48	60,69	60,88	61,05	61,21	61,35	61,48	61,59	
<b>350</b>	Sn [m <sup>2</sup> ]	0,1659	0,1778	0,1898	0,2017	0,2137	0,2256	0,2376	0,2495	0,2615	0,2734	
	Sn [%]	64,81	65,10	65,36	65,59	65,80	65,98	66,15	66,30	66,44	66,57	
<b>400</b>	Sn [m <sup>2</sup> ]	0,2006	0,2150	0,2295	0,2439	0,2584	0,2728	0,2873	0,3017	0,3162	0,3306	
	Sn [%]	68,42	68,73	69,00	69,25	69,47	69,66	69,84	70,00	70,14	70,28	
<b>450</b>	Sn [m <sup>2</sup> ]	0,2353	0,2522	0,2692	0,2861	0,3031	0,3200	0,3370	0,3539	0,3709	0,3878	
	Sn [%]	71,22	71,54	71,83	72,08	72,31	72,51	72,69	72,86	73,01	73,15	
<b>500</b>	Sn [m <sup>2</sup> ]	0,2630	0,2820	0,3009	0,3199	0,3388	0,3578	0,3767	0,3957	0,4146	0,4336	
	Sn [%]	71,56	71,89	72,18	72,43	72,66	72,86	73,05	73,21	73,37	73,51	
<b>550</b>	Sn [m <sup>2</sup> ]	0,2977	0,3192	0,3406	0,3621	0,3835	0,4050	0,4264	0,4479	0,4693	0,4908	
	Sn [%]	73,56	73,89	74,19	74,45	74,68	74,89	75,08	75,26	75,41	75,56	
<b>600</b>	Sn [m <sup>2</sup> ]	0,3324	0,3564	0,3803	0,4043	0,4282	0,4522	0,4761	0,5001	0,5240	0,5480	
	Sn [%]	75,22	75,56	75,86	76,13	76,37	76,58	76,78	76,95	77,12	77,26	
<b>650</b>	Sn [m <sup>2</sup> ]	0,3671	0,3936	0,4200	0,4465	0,4729	0,4994	0,5258	0,5523	0,5787	0,6052	
	Sn [%]	76,62	76,97	77,28	77,55	77,79	78,01	78,21	78,39	78,55	78,70	
<b>700</b>	Sn [m <sup>2</sup> ]	0,4018	0,4308	0,4597	0,4887	0,5176	0,5466	0,5755	0,6045	0,6334	0,6624	
	Sn [%]	77,82	78,18	78,49	78,76	79,01	79,23	79,43	79,62	79,78	79,94	
<b>750</b>	Sn [m <sup>2</sup> ]	0,4365	0,4680	0,4994	0,5309	0,5623	0,5938	0,6252	0,6567	0,6881	0,7196	
	Sn [%]	78,86	79,22	79,53	79,81	80,07	80,29	80,49	80,68	80,85	81,00	
<b>800</b>	Sn [m <sup>2</sup> ]	0,4712	0,5052	0,5391	0,5731	0,6070	0,6410	0,6749	0,7089	0,7428	0,7768	
	Sn [%]	79,77	80,13	80,45	80,73	80,99	81,21	81,42	81,61	81,78	81,94	

## Sample order

CU2-15	400	300	PG30	PM	CFTH	FCU
1	2	3	4	5	6	7

1. product
2. width
3. height
4. frame on the side of the mechanism
5. frame on the side of the wall
6. mechanism type
7. option: uni/bipolar switches

## Approvals and certificates

All our dampers are submitted to a number of tests by official test institutes. Reports of these tests form the basis for the approvals of our dampers.



0749-CPR-BC1-606-0464-15650.04-0464&2517



18.13



2822-UKCA-CPR-0058

The NF-label guarantees: conformity with the standard NF S 61-937 Parts 1 and 5: "Systèmes de Sécurité Incendie Dispositifs Actionnés de Sécurité"; conformity with the national decree of March 22, 2004, changed on 14 March 2011 for the classification of fire resistance; the values of the characteristics mentioned in this document. Organisme Certificateur: AFNOR Certification, 11 Rue Francis de Pressensé, F93571 La Plaine Saint-Denis Cedex; Website: <http://www.afnor.org> and <http://www.marque-nf.com>; Phone: +33 (0)1.41.62.80.00, Fax: +33 (0)1.49.17.90.00, Email: [certification@afnor.org](mailto:certification@afnor.org)